



# YAK/IBEX OWNER'S MANUAL

(800) 893-2447 www.bobgear.com  
13501 South Ridge Drive, Charlotte, North Carolina 28273

1  
OMT01C

BOB is a company that produces high quality products, which encourage a healthy, outdoor, car-free lifestyle. In addition to trailers, we also make full suspension jogging strollers. See [www.bobgear.com](http://www.bobgear.com) for our complete line of products. **Before attempting to assemble or use your new trailer, read and understand these instructions completely to insure proper assembly and operation.** If you are unclear on any point, contact your dealer or BOB before use.

## ⚠ WARNINGS ⚠

- BOB trailers can be attached to bicycles with wheel sizes between 20" and 28". Please see the Trailer/Bike Compatibility chart at the end of this manual to determine which trailer is compatible with your bike. The wheel size appears as a raised surface on the side-wall of the bicycle tire. If your wheels do not meet these diameter specifications, it is unsafe for you to attach the trailer. If you have questions about your wheel diameters or trailer compatibility with your bicycle, consult your bicycle dealer or call us at BOB.
- Our trailers are intended to carry cargo only.
- Do not carry children or live animals.
- Cargo capacity: 70 pounds (32 kilograms)
- The more weight you add to the trailer, (just like a car) the more effect it will have on the handling of your bicycle.
- All cargo must be securely fastened to the trailer frame. Shifting loads can adversely affect bicycle handling and result in loss of control.
- Keep the cargo center of gravity low.
- The load height above the mesh platform should never exceed 18 inches (46cm). Loads higher than 18" can adversely affect bicycle handling and result in loss of control.
- QR length must be correctly sized to your specific bicycle to insure safe operation.
- Make sure your bike's brakes are in top condition and properly adjusted. Always allow extra stopping distance when riding with your trailer. Marginally performing brakes will be inadequate for safe braking with the added load of a trailer. When riding in wet conditions use extreme caution and allow even more distance for braking.
- Generally, car drivers don't expect bicycles to be pulling trailers. Use the included BOB safety flag to be seen!
- When passing another cyclist, remember that you are approximately 4.5 feet (140cm) longer than your bike alone!
- The YAK & IBEX come with wheel and fender reflectors for night visibility. Check that the reflectors on both your bicycle and trailer are properly installed. Installation procedures follow in this manual. Contact your appropriate state government office to learn of the lighting requirements for your state / country.
- **SPEED LIMIT:** 25 mph (40 kph) A bike with trailer attached, steers and feels different. Ride cautiously. Speed wobbles (and loss of control) can occur if speed limit is exceeded.
- It is CRITICAL that the wheels and tires of your bicycle and trailer are properly maintained (see your bike dealer) and inflated to the normal operating pressure embossed on the sidewall.
- Some full suspension bicycles and rear suspension recumbents do not have adequate frame stiffness to offset the forces of a fully loaded, moving trailer. The result can be a bike that is sluggish, difficult to control or stop which could lead to a crash (and/or damage to the trailer or contents). We strongly recommend test riding (braking and turning) the bike with a full, non-human, test load [70 lbs (32kgs)] in a cautious manner (in an area absent of traffic hazards) to determine if this condition exists. This condition could be exacerbated by wet, sandy, or gravel covered surfaces.
- Some variables that can affect the control of your bike and trailer: improper installation of BOB QR / improper installation of trailer fork retaining pins to BOB QR / improper installation of trailer fork to YAK & IBEX frame / road conditions / wind speed and direction / cyclist's skill level / weight of rider relative to the amount of weight in trailer / center of gravity of cargo / integrity of all wheels (proper spoke tension and bearing adjustment)
- Rear racks and panniers are sometimes used in conjunction with the trailers. With some frames (usually smaller sizes) it is possible for the bottom of the pannier to come in contact with the top of the retention pin. This can cause the pin to release resulting in the unexpected detachment of the trailer. This can lead to loss of control and injury. Make certain that this condition does not exist. If it appears to be a problem, using our older style pin (PI9500) may eliminate this problem.

## ⚠ CAUTION ⚠

- Attach and detach the trailer ONLY when it is in a straight line with the bike. You can bend the fork otherwise. It is easiest to attach and detach trailer when it is unloaded.
- Protect all sharp objects from puncturing DRY SAK.
- The YAK & IBEX forks must be limited to approximately 20 degrees of rotation to avoid contacting the rear derailleur and possibly bending the mount. (FIG. 2). This can happen when riding over large, fallen trees, lifting the bike and trailer, or possibly when utilizing the "park mode" feature (Fig. 31). Check the amount of clearance your bike's derailleur has before riding.

## BOX CONTENTS

This box/package should contain the following parts; check to make sure before starting to assemble; if there are parts missing or you need replacement parts please call customer service M-F 8:30 am - 5 pm MST at 208-375-5171 or 800-893-2447. Do not use any substitute non-original parts as this may lead to premature failure of the product.

- Fork/Frame Assembly
- Swing Arm/Shock Assembly (IBEX only)
- Fender, Fender Reflector, & mounting hardware (YAK only)
- Wheel Reflectors
- BOB QR
- Trailer Wheel
- Trailer Wheel QR
- Flag with Flag Pole
- Spare Attachment Pin
- Bungee Cord
- Owner's Manual
- Dry Sak (YAK Plus & IBEX Plus only)

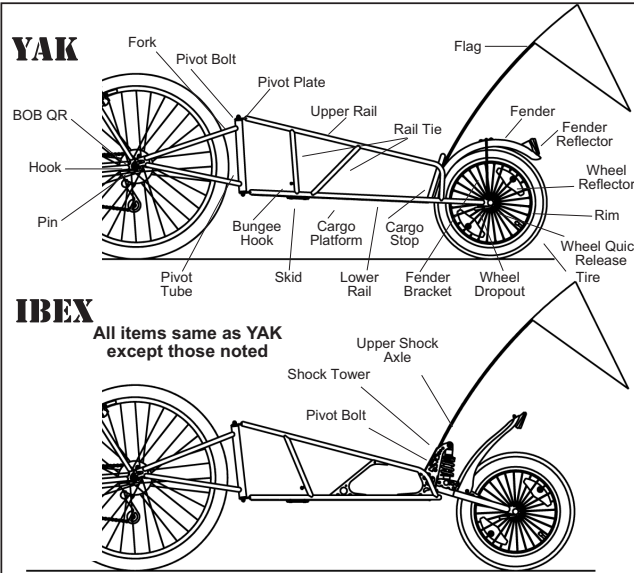

FIG. 1  
Trailer Anatomy (YAK & IBEX).

## ASSEMBLY INSTRUCTIONS

**Before proceeding with the trailer assembly and installation, you should confirm your bike and trailer are compatible with one another. Reference the Trailer/Bike Compatibility chart at the end of this manual.**

### BOB Quick Release or BOB Nutz ...what do you need?

Most modern bicycles use a quick release mechanism (QR) to secure wheels to the bicycle. The YAK & IBEX trailers are attached to the bicycle with a specially designed BOB QR. The BOB QR replaces the bikes original rear QR, and has a trailer attachment point on both ends. We make our QRs in three lengths (standard, 145mm (tandem), and Santana/160mm). If your bike does not use a QR to hold on the rear wheel, you will need a pair of BOB Nutz. BOB Nutz and Quick Release specifications are listed at end of manual.

**NOTE: BOB TRAILERS INC. IS NOT RESPONSIBLE FOR INJURY, DAMAGE, OR FAILURE THAT RESULTS FROM FAULTY ASSEMBLY OR MAINTENANCE AFTER RECEIPT OF PRODUCT.**

- Tools Needed:**
- Two 4mm hex wrenches (allen wrenches)
  - Two 10mm wrenches (or adjustable wrenches)
  - 8 mm wrench (YAK only)
  - Phillips screwdriver (YAK only)
  - Slotted screwdriver

**For some older bikes with dropout spacing below 135mm:**  
Metal cutting saw  
Metric die or nut; 5mm x .8mm  
Metal file



FIG. 2  
Trailer in extreme counter-clockwise rotation showing contact between derailleur pivot housing and trailer fork. AVOID this condition. If you believe this has occurred, inspect your derailleur, QR, and pins for damage.

**1. UNPACK:** Remove trailer, small parts box and box contents, Dry SAK, etc. Plastic packaging material was used to protect the rear dropouts and the wheel axes. Remove these plastic pieces as well as all other packaging material.

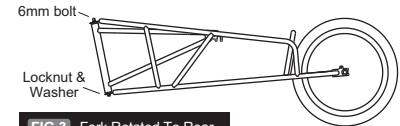

FIG. 3 Fork Rotated To Rear.

**2. FORK ASSEMBLY:** For shipping purposes, the trailer fork has been attached to the frame pointing to the rear of the trailer, Fig. 3. The fork will need to be removed and rotated 180 degrees, and then reattached prior to use, as shown in Fig. 4.

**A)** Remove the lock nut (Fig. 3, using two 10mm wrenches) and flat washer then fully remove the long 6mm bolt. This will free the fork from the trailer frame. Remove the fork. To reinstall the fork pointing forward, align the holes in the pivot plates of the trailer frame and the pivot tube in the fork as shown in Fig. 4.

**B)** Insert the long 6mm bolt with a washer on each end then tighten the lock nut, Fig. 4. Tighten the lock nut to 60 inch-pounds (70 cm-kgs).

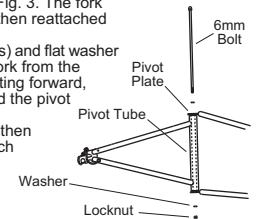

FIG. 4 Rotated Fork & Bolt Assembly.

### 3. SWING ARM INSTALLATION (IBEX ONLY):

**A)** Begin by first removing the pivot bolt and washers, Fig. 1, using two 10mm wrenches.

**B)** Next install the swingarm pivot in the shock tower.

The pivot is wider than the shock tower opening and will need to be twisted so the left bushing/side of the swingarm goes through the opening first and exits the left side window as shown in Fig. 5.

**C)** To get the right side bushing inside the tower, align it with the upper right hand corner of the tower opening as shown in Fig. 6 and rotate forward. The pivot should now be inside the shock tower. You will install the pivot bolt after installing the upper shock bolt.

**D)** Remove the upper shock axle, Fig. 1. Align the shock axle with the holes in the shock tower and install the axle and washer, Fig. 7, and tighten to 60 inch-pounds (70 cm-kgs) using two 5mm Allen wrenches.

**E)** The pivot axle will need to be aligned with the pivot bolt holes in the shock tower. These are located above and forward of the windows in the sides of the tower. The fit between the pivot axle and tower is a tight tolerance fit so it will take some effort to move the pivot into position. This can be done by pushing on the back of the swingarm and rotating the pivot axle into alignment with the pivot bolt holes as shown in Fig. 8. Once aligned, install pivot bolt and washers, Fig. 8, and tighten to 60 inch-pounds (70 cm-kgs) using two 10mm wrenches.

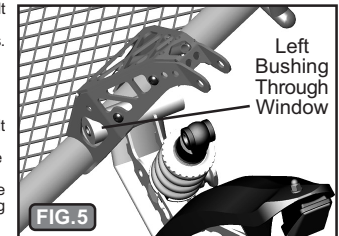

FIG. 5

Left Bushing through shock tower opening and left window.

### 4. FENDER ASSEMBLY (YAK ONLY):

**A)** Fender Reflector Installation - The fender reflector attaches to the rear portion of the fender. The reflector has a threaded stud built into it. Attach the reflector to the fender by inserting the stud into the upper hole and the plastic "alignment pin" into the lower hole of the fender as shown in Fig. 9. Next, place the washer over the portion of the stud extending through the underside of the fender. Thread the nut on and tighten with an 8mm wrench.

**B)** Fender Bracket Attachment - First, attach the fender bracket to the fender. Place the fender bracket in the center of the two holes in the fender and align the mounting hardware with them as shown in Fig. 10. Insert the screws through the holes from the outside of the fender. Place the threaded backing plate on the inside of the fender and tighten the screws using a screwdriver.

**C)** Fender Attachment - The fender attaches to the trailer in three places. Begin by removing the screw and washers from the forward fender mount on the trailer frame. Attach the fender to the trailer by inserting the bolt and washer through the slot in the fender. Next place the second washer behind it (sandwiching the fender with washers) as shown in Fig. 11. Tighten the bolt securely with a 4mm Allen wrench. Next, attach the fender brackets to the left and right dropouts. Insert the bolt through the washer and then through the loop in the fender bracket as shown in Fig. 12. Align the bolt with the eyelet in the dropout and tighten securely with a 4mm Allen wrench.

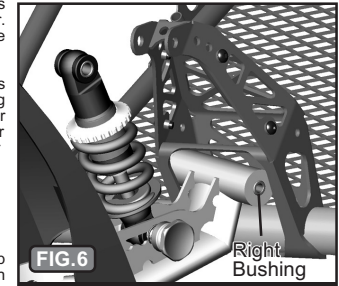

FIG. 6

Right Bushing aligned with upper right shock tower opening.

**5. WHEEL REFLECTORS:** The trailer comes with two spoke reflectors which mount onto the spokes of the trailer wheel.

**A)** Reflectors should be mounted 90 degrees from the valve stem, Fig. 13. The reflectors should be installed by weaving them through the spokes. The reflectors attach to the spoke with the white slotted attachment "screw", Fig. 14. Remove attaching screw from reflector. Place reflector in position between wheel spokes and centered on a spoke approximately 90 degrees from valve stem.

**B)** Install screw, Fig. 14, over spoke and into receiving hole of reflector. Using a screwdriver, turn screw 90 degrees clockwise to lock reflector in position. Repeat the above steps for the second reflector to be installed opposite the position of the first reflector. This reflector configuration will keep the trailer wheel balanced and vibration free.

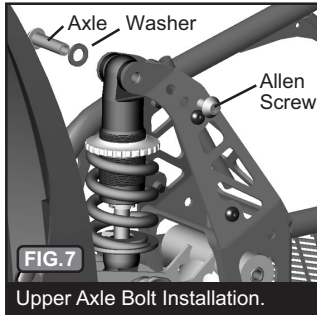

FIG. 7  
Upper Axle Bolt Installation.

**6. YAK & IBEX WHEEL INSTALLATION USING QR (FIG. 15):** *NOTE: Follow all instructions exactly. If you are unsure how to operate the quick release, please consult your bicycle dealer or contact BOB. Fig. 15 shows the anatomy of the quick release.*

**A)** Remove adjust nut and one spring from the quick release.

**B)** Insert the quick release rod through the hole in the axle.

**C)** Install the second spring with the small end pointing towards the hub then install adjust nut.

**D)** Slide wheel into the dropouts, FIG. 16, and confirm wheel is centered between the wheel stays.

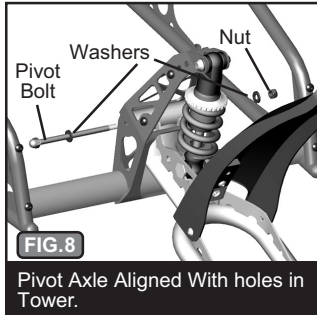

FIG. 8  
Pivot Axle Aligned With holes in Tower.

**IMPORTANT:** The quick release is NOT a nut and bolt system. It is a cam-activated tightening mechanism. Tighten the QR as follows:

**E)** Move the QR lever perpendicular (at a 90 degree angle) to the trailer, FIG. 16.

**F)** Turn the adjusting nut until it comes in contact with the trailer dropout.

**G)** Move the quick release lever to the closed position, FIG. 17. The word CLOSE should be clearly visible on the lever and it should be parallel to the wheel stay.

**H) NOTE:** It should require considerable pressure to close the lever when it is properly adjusted. If you do not feel this resistance, turn the quick release lever back to the adjusting position, FIG. 16, and tighten the adjust nut by hand (it is not necessary to use tools) one or two more turns in the clockwise direction then move the quick release lever to the closed position, FIG. 17. When properly adjusted, it requires 80-105 inch - pounds of torque to move the lever to the fully closed position.

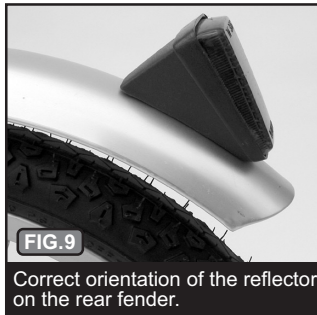

FIG. 9  
Correct orientation of the reflector on the rear fender.

**7. SAFETY FLAG: IMPORTANT:** The flag is extremely important in making you and your

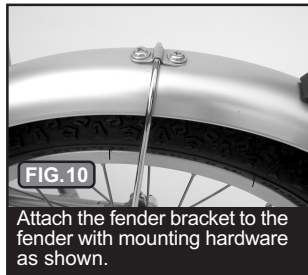

FIG. 10  
Attach the fender bracket to the fender with mounting hardware as shown.



FIG. 11  
Attachment of fender to trailer frame.

trailer visible to others. Always make sure the flag is correctly installed when using your trailer.

**A)** Press the two metal ends (silver) of the flag sections together making sure they insert into one another completely.

**B)** Install completely into the flag tube. On the YAK the flag tube is located on the left side of the cargo stop, FIG. 18. On the IBEX it is located in the middle of the shock tower, FIG. 19.

**8. BOB QUICK RELEASE (QR) INSTALLATION:**

**IMPORTANT:** Bicycle manufacturers use a large variety of components and materials to build their bikes and the thickness of the rear wheel dropouts vary greatly. It is extremely important to have your BOB QR sized to the appropriate length and correctly installed on your bike. Please note the dropout inside dimension assumes that the dropouts are firmly pressed against the hub axle over locknuts, alleviating any gap between the two and allowing for an accurate measurement. The QR's primary role is to secure the rear wheel to your bike, and secondarily, it is the structural link between the bike and trailer. For a QR to work properly, the QR rod must extend past the dropout on the derailleur side by a minimum of 3/8 inch (10mm) and maximum of 3/4 inch (19mm). Fig. 20 shows the anatomy of the BOB Quick Release.

**A)** Remove the bike's rear QR. Remove the adjust nut and one conical spring from the BOB QR and install into the rear wheel axle hole on the non-derailleur side.

**B)** With the QR cam lever in the closed position (note that "CLOSE" is visible on the cam lever) push the quick release through the bike's rear axle until it contacts the bike frame dropout face.

**C)** Check for a minimum of 3/8 inch (10mm) and maximum 3/4 inch (19mm) of threaded rod extending past the dropout face, Fig. 21. **IMPORTANT:** If the amount of rod extending past the dropout face is less than 10mm, you will need a longer quick release. Please consult the BOB Quick Release Model table at the end of this manual to find the correct QR for your bike.

If the amount of rod is greater than 19mm, see the next section: "TRIMMING THE BOB QR ROD". If you do not understand this section, contact your local bike dealer or call BOB for help.

**D)** Install the 2nd conical spring onto the QR rod (small hole first) and then the adjust nut.

**E)** With the QR lever perpendicular (at a 90 degree angle) to the frame, Fig. 22, tighten the adjusting nut clockwise until it is snug against the dropout face.

**F)** Move the QR lever until "CLOSE" is visible on the lever, Fig. 23, and it is parallel to the frame. **IMPORTANT:** For highest strength, it should require considerable pressure to close the QR lever when it is properly adjusted and tightened.

**G)** If you do not feel this resistance turn the quick release lever back to the adjusting position, Fig. 22. Tighten the QR adjust nut by hand (it is not necessary to use tools) one or two more turns in the clockwise direction. Proper adjustment requires 80 to 105 inch - pounds of torque to move the lever to the fully "CLOSED" position.

**9. TRIMMING THE BOB QR ROD:** If your QR rod measurement (see above section, step "C") exceeds 3/4 inch (19mm), proceed with the following:

**A)** If your measurement is 25 mm (for example), subtract 19 mm (max. length) to determine length of rod to be cut. (25 - 19 = 6mm.) As a general rule, it is recommended to maximize the length of the rod.

**B)** Thread a 5mm x .8mm nut or threading die onto the QR rod past the area to be cut. (after trimming the QR rod, the nut / die will clean up the threads



FIG. 12  
Attachment of fender bracket to dropout eyelet.



FIG. 13  
Wheel reflector correctly positioned.

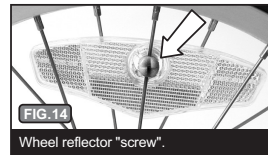

FIG. 14  
Wheel reflector "screw".

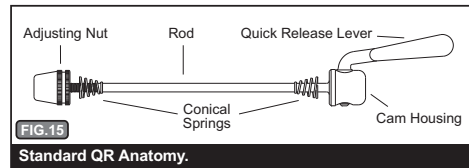

FIG. 15  
Standard QR Anatomy.



FIG. 16  
QR lever perpendicular to drop out face.



FIG. 17  
QR lever closed.

when it is removed).

**C)** Clamp the QR rod in a vise, being careful not to damage the threads, Fig. 24.

**D)** Measure from the tip of the QR rod and cut the rod with a metal cutting saw.

**E)** Using a file, shape the end of the rod into a conical shape.

**F)** Remove the nut (or die) and verify the QR rod has been cut to the proper length by repeating steps B and C in the previous section then complete QR installation by following steps D through G in previous section.

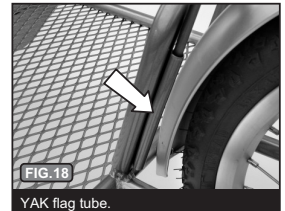

FIG. 18  
YAK flag tube.

**10. TRAILER ATTACHMENT:** Now that the BOB quick release is correctly installed, attach the trailer to the quick release. To do this correctly, follow the steps below:

**A)** The stainless steel pivoting BOBBINS on the quick release skewer are asymmetrical as shown in Fig. 20. This asymmetrical design allows the BOBBINS to be reversed, allowing for a variance of approximately 13mm in outside dimensional span of the bike's dropouts.

**B)** With the bike stabilized and the trailer unloaded, check the fit between the fork hooks and the slots of the BOBBINS. It is easiest to do this with the bike in the upright-position and trailer straight behind the bike. Stand on the left side of the bike facing towards the trailer. Allow the bike seat to rest against your hip. Bend at the hips and lift trailer with both hands, Fig. 25, and place the fork hooks on the quick release BOBBINS. If the hooks do not fit into the BOBBIN slots by slightly expanding or compressing the fork, it will be necessary to reverse the BOBBINS. Fig. 26 shows a situation where the hooks do not fit easily and the BOBBINS need to be reversed.

**C)** With the quick release installed, and using a 4mm Allen wrench, remove the BOBBIN retaining screws, Fig. 20, on both the left and right sides. Remove the BOBBINS and reverse them noting the position of the lock and flat washers.

**D)** With the BOBBINS reversed, reinstall the retaining screws and lock washers. Tighten the

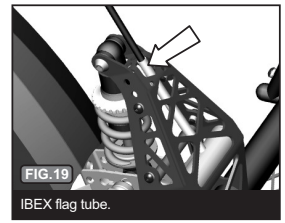

FIG. 19  
IBEX flag tube.

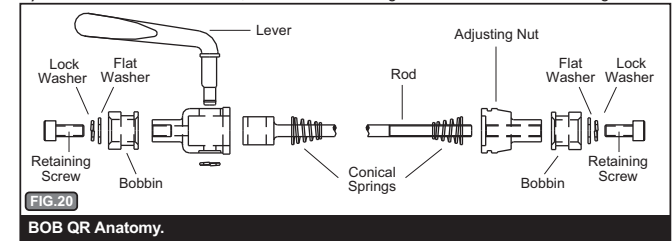

FIG. 20  
BOB QR Anatomy.

retaining screws securely.

**E)** Attach the trailer by aligning the slots of the BOBBINS with the slots in the fork hooks. Fig. 27 shows the fork hooks correctly installed on the BOBBINS.

**F)** With the trailer hooks placed on the bobbins, insert the pin in the hole in the front edge of the hook. Slide the pin under the bobbin and into the hole in the back edge of the hook. Rotate the pin up, toward the button head post on the hook. To secure the pin, it is necessary to press it downward and toward the hook. When properly installed, the pin fits between the hook and the head on the button head post, as shown in Fig. 28. The rubber lanyard retains the pin when not installed.

**IMPORTANT:** The pins are CRITICAL to keeping the trailer attached to the BOB Quick Release. Inspect pins for proper installation every time you ride. Incorrectly installed pins can allow the trailer to detach from the bicycle and cause a severe accident. Please see your dealer or call BOB if you do not understand the pin installation procedure.

**11. SHOCK STIFFNESS ADJUSTMENT (IBEX ONLY):**

The IBEX trailer has three shock stiffness settings depending on the weight of the load you are carrying. It is important to correctly adjust the shock each time you change the load in the trailer to keep from bottoming out of the suspension system. Repeated bottoming out of the suspension system will shorten the life of the trailer frame, swing arm, and shock assembly. To adjust the suspension stiffness proceed as follows:

**A)** Unweight the trailer wheel by lifting the

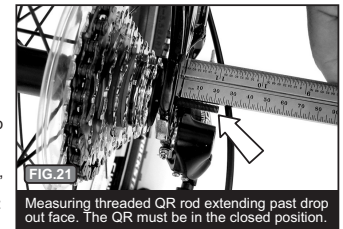

FIG. 21  
Measuring threaded QR rod extending past drop out face. The QR must be in the closed position.

trailer by the frame. This should be done with the trailer empty.

**B)** Fully depress the shock adjustment button on the right side, Fig. 29.

**C)** While holding down the button, slide the shock to the desired setting.

**D)** Release the button and pull swing arm back and forth until the button snaps into place.

**Position 1 (forward most position) is the softest setting and Position 3 (rearward most position) is the stiffest.** As a general rule use the following guidelines when setting up the suspension system:

Position 1: 0 - 25 lbs (0 - 11 kg) of cargo.  
Position 2: 25 - 45 lbs (11 - 20 kg) of cargo.  
Position 3: 45 - 70 lbs (20 - 32 kg) of cargo.

**12. DRY SAK:** Loading tips: Make sure all sharp objects are covered to prevent punctures of the DRY SAK wall. Place heaviest objects in the bottom for maximum stability.

**Closing procedure to insure DRY SAK is watertight:**

**A)** Load Bag, Fig.30

**B)** Bring the 2 black plastic strips together at the rim of the SAK.

**C)** Roll strips together as you would a paper bag and synch tight with the end buckles.

**D)** Connect center buckle over the 2 handles and synch tight.

**Securing in trailer:**

**E)** Place black section of SAK towards rear. Hook spider bungee to frame tubes and / or bungee hooks to retain DRY SAK cargo.

## PARKING TIPS

• If possible park your bike and trailer on level ground.

• Rest trailer on a curb against the parking skid (FIG. 1) lean it against a building, fence, or sign

• **PARK MODE:** Fig. 31 shows the bike and trailer in "Park Mode". Turn the bike 90 degrees to the trailer with handlebars turned 90 degrees to the bike. Lower trailer frame to the ground, contacting the parking skid (FIG. 1) and the trailer will stand up on its own. **NOTE:** This feature works best when the trailer is loaded and does not work on all bikes.

• To "un-park" your bike, place one hand on the handlebars, and one hand on the seat while walking forward and pulling the seat towards you as the trailer will stabilize in the horizontal position.

• A standard kick stand for your bicycle works well in most circumstances to keep the bike and trailer upright.

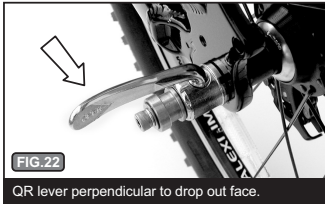

FIG. 22  
QR lever perpendicular to drop out face.

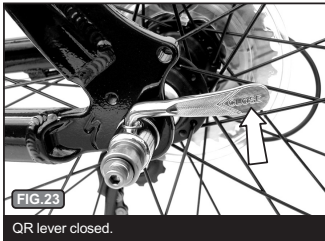

FIG. 23  
QR lever closed.



FIG. 24  
QR with die in place and clamped for cutting.



FIG. 25  
Correct position for bike and trailer attachment.

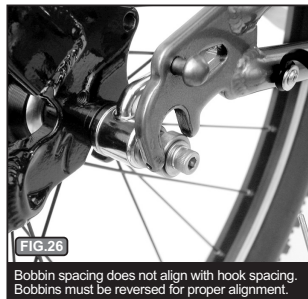

FIG. 26  
Bobbin spacing does not align with hook spacing. Bobbins must be reversed for proper alignment.

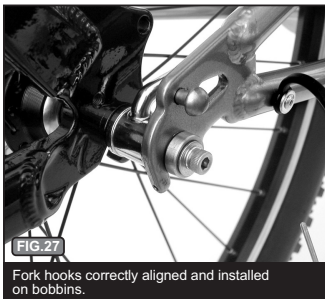

FIG. 27  
Fork hooks correctly aligned and installed on bobbins.

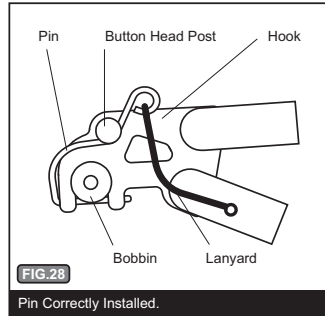

FIG. 28  
Pin Correctly Installed.

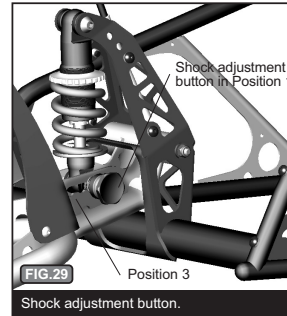

FIG. 29  
Shock adjustment button.

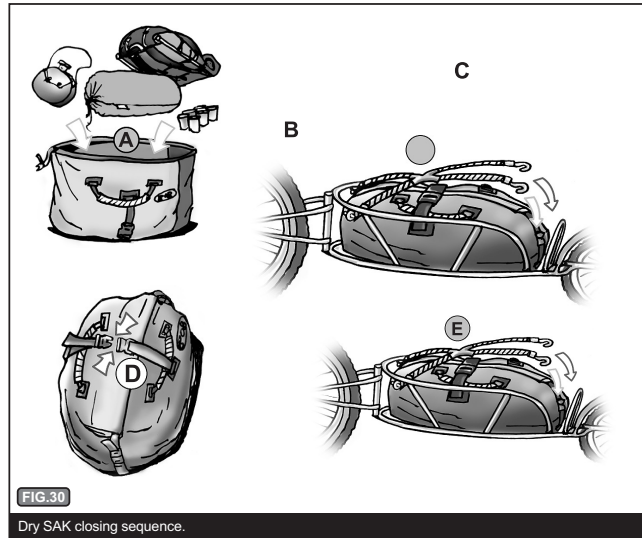

FIG. 30  
Dry SAK closing sequence.

**CAUTION:** A small percentage of bike's rear derailleurs are positioned such that when parked, the fork of the YAK contacts the derailleur pivot housing. Fig. 2 Verify with a friend that there is adequate clearance before leaning the bike and trailer completely over in park mode. Note: reversing the installation of the QR (install from the drive side / right side of bike) helps eliminate this problem. BOB TRAILERS assumes no responsibility for bent derailleurs that result from the owner neglecting to check for proper clearance prior to utilizing "PARK MODE".

## LIMITED WARRANTY

BOB Trailers Inc. takes pride in its workmanship and strives to manufacture the best products possible. Therefore, we warranty our YAK and IBEX trailers against defects in material and workmanship subject to the conditions listed below. Since no product is indestructible, it does not cover defects attributable to or resulting from normal wear, abuse or alteration.

BOB Trailers, Inc. warrants original parts of

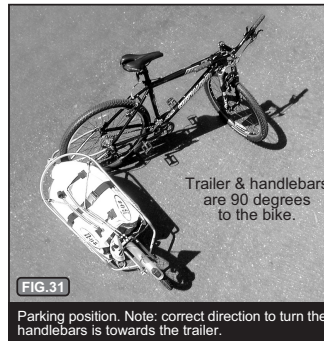

FIG. 31  
Parking position. Note: correct direction to turn the handlebars is towards the trailer.

BOB Trailers products to be free from defects in materials and workmanship subject to the following conditions and limitations:

- Frame is warranted for five years.
- Components are warranted for one year.
- Warranty is only valid for the original purchaser.
- Proof of purchase is required to exercise this warranty.
- Labor and transportation are not included.
- Normal wear, neglect, abuse, accidents, improper assembly or maintenance, or the installation of parts or accessories not compatible with the original intended use of the trailer, as sold, are not covered by this warranty.
- Warranty claims must be made through an authorized dealer.
- This warranty is limited to the replacement of the defective part. BOB Trailers shall in no event be responsible for consequential or special damages.
- This limited warranty is the only express or implied warranty applicable to BOB Trailers. Any implied warranties, including warranties of merchantability and fitness shall be limited in scope and duration in accordance with this limited warranty.

## MAINTENANCE SCHEDULE

| Part                    | Service                         | Period**   |
|-------------------------|---------------------------------|------------|
| <b>B.O.B QR</b>         | Check tightness                 | Every ride |
| <b>QR BOBBINS</b>       | Check for wear & damage         | Monthly    |
|                         | Check retaining screw tightness | Every ride |
| <b>Hub Bearings</b>     | Remove and clean bushing        | Monthly    |
|                         | Replace                         | As needed  |
| <b>Retaining Pins</b>   | Check for smooth rotation       | Monthly    |
|                         | replace*                        | As needed  |
| <b>Tire</b>             | Inspect                         | Every ride |
| <b>Fork</b>             | Check Pressure                  | Weekly     |
|                         | Inspect for damage              | Monthly    |
| <b>Fork Bushings</b>    | Check pivot screw tightness     | Weekly     |
| <b>Wheel</b>            | Check for looseness*            | Yearly     |
| <b>Wheel QR</b>         | True*                           | As needed  |
| <b>IBEX only</b>        | Check tightness                 | Every ride |
| <b>Swingarm pivot</b>   | Check retaining bolt tightness  | Weekly     |
| <b>Upper Shock bolt</b> | Check bolt tightness            | Weekly     |

\*We recommend this service be performed by a trained bicycle mechanic at a professional bicycle dealership. This requires special tools and skill.

\*\*May require more frequent service if you ride in wet, sandy, or dusty conditions. All the above frequencies are intended as guidelines. Depending on where you ride and your riding style, these services may need to be performed more frequently.

## TRAILER/BIKE COMPATIBILITY

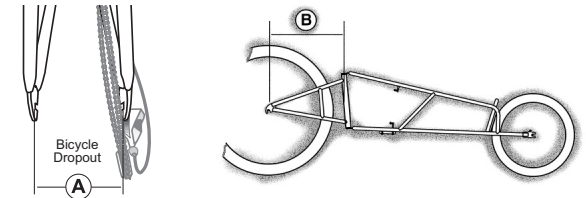

| Trailer Model    | A - Dropout Spacing Compatibility | Included BOB Quick Release | Included BOB Fork | B - Fork Clearance | Wheel Diameter Range |
|------------------|-----------------------------------|----------------------------|-------------------|--------------------|----------------------|
| IBEX / IBEX PLUS | 126.5 - 140mm                     | Standard QR                | Standard          | 360mm*             | 20" - 27"            |
| YAK / YAK PLUS   | 126.5 - 140mm                     | Standard QR                | 28                | 420mm**            | 20" - 28"            |
| YAK PLUS SANTANA | 160mm                             | Santana QR                 | Santana           | 360mm*             | 20" - 27"            |

Please note there are some bikes that have 145mm dropout spacing. We make a 145mm QR for use with these bikes. The 145mm QR is compatible with the IBEX, IBEX Plus, YAK, YAK Plus, YAK 28 and YAK 28 Plus.

\* Fits 20", 26" & 700c wheels without fenders  
\*\* intended for bikes with 28" wheels or bikes with 700c/27" wheels and full wrap fenders and reflectors



## BOB NUTZ MODELS

BOB Nutz are special adapters for bicycles with solid axles, replacing the original nuts and giving an attachment point at either extremity of the axle. We make four BOB Nutz models to fit different axle configurations (See chart below).

| BOB Nutz Model           | Axle Diameter | Thread Pitch | Common Applications   |
|--------------------------|---------------|--------------|---|
| 3/8 x 24                 | 3/8 inch      | 24 tpi       | Single speed coaster brake hubs   |
| 3/8 x 26                 | 3/8 inch      | 26 tpi       | Shimano Nexus 4 and 7 speeds,<br>Shimano 3 speed coaster brakes,<br>English and Japanese solid axles                  |
| 10 x 1                   | 10mm          | 1mm          | ISO and Japanese solid axles  |
| IGH (Internal Gear Hubs) | 10.5mm        | 1mm          | Sachs multi-speed hubs with indicator chain shifting<br>Sturmey Archer multi-speed hubs with indicator chain shifting |
|                          | 13/32 inch    | 26 tpi       |   |

## BOB QUICK RELEASE MODELS

The BOB Quick Release comes in three different models to fit a wide range of rear hub spacings:

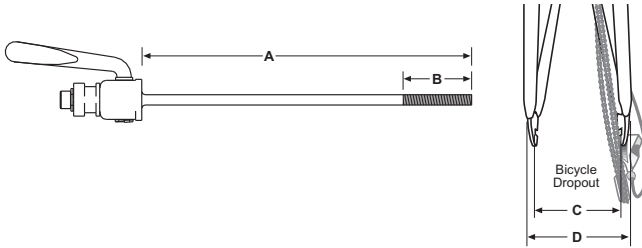

| QR Model       | A Rod Length | B Threaded Length | C Dropout Inside Dimension | D Allowable Dropout Outside Dimension |
|----------------|--------------|-------------------|----------------------------|---------------------------------------|
| BOB QR         | 165mm*       | 32mm              | 126.5 - 140mm**            | 140 - 156mm                           |
| BOB 145 QR     | 175mm*       | 35mm              | 145mm**                    | 145 - 164mm                           |
| BOB Santana QR | 190mm*       | 30mm              | 160mm**                    | 165 - 180mm                           |

\*Measurement is with QR lever in closed position

\*\*Dropout inside dimension (C) to measure the same as bicycle hub's axle over locknut dimension.